

5MP Fixed IR Bullet Analog Camera

UAC-B115-AF28(40)



Overview

UAC-B115-AF28(40) is a 5MP fixed IR bullet analog camera with a high-performance 1/2.7-inch CMOS sensor. It supports TVI/AHD/CVI/CVBS, which effectively enhances product adaptability and diversity of networking solutions. With SYV-75-3 or other coaxial cable types, the camera can achieve low-cost, long-distance, and anti-interference mega-pixel HD video transmission without time delay. It supports IR-cut filter with auto-switch (ICR) and provides color images at daytime and black/white images at night. The camera also supports audio input and synchronous transmission of audio and video.

Features

- 5MP high quality image TVI/AHD/CVI/CVBS
- Supports IR-cut filter with auto-switch (ICR)
- Supports 180 horizontal flip, 180 vertical flip
- OSD configuration menu, easy to operate
- IP67 waterproof and dustproof design, high reliability
- OSD configuration menu in 11 languages
- Built-in microphone for high quality audio transmission via coaxial cables

Specifications

| Sensor | Description |
|--------|-------------------|
| Pixel | UAC-B115-AF28:5MP |

| | |
|-------------------------|---|
| Sensor Size | UAC-B115-AF28:1/2.7" CMOS |
| Min. Illumination | UAC-B115-AF28:0.02 lux (F2.0, AGC ON) 0 lux (IR ON) |
| Lens | Description |
| Focus | UAC-B115-AF28:2.8 mm |
| Lens Mount | UAC-B115-AF28:M12 |
| Angle of View (H) | UAC-B115-AF28:102.2° |
| Angle of View (V) | UAC-B115-AF28:53.9° |
| Angle of View (D) | UAC-B115-AF28:124.8° |
| Illuminator | Description |
| Illuminator Number | UAC-B115-AF28:One IR illuminator |
| Illumination Distance | UAC-B115-AF28:20m |
| Lifetime | UAC-B115-AF28:≥60000 hours |
| Video | Description |
| Resolution | UAC-B115-AF28:5MP@25fps: 2880(H)×1620(V); 5MP@20fps: 2592(H)×1944(V); 5MP@12.5fps: 2592(H)×1944(V) 4MP: 2560(H)×1440(V) 1080P: 1920(H)×1080(V) |
| Frame Rate | UAC-B115-AF28:TVI: 5MP@20fps (default), 5MP@12.5fps, 4MP@25fps, 4MP@30fps, 1080P@25fps, 1080P@30fps AHD: 5MP@20fps, 4MP@25fps, 4MP@30fps, 1080P@25fps, 1080P@30fps CVI: 5MP@25fps, 4MP@25fps, 4MP@30fps, 1080P@25fps, 1080P@30fps CVBS: PAL, NTSC |
| Shutter Time | UAC-B115-AF28:PAL: 1/25s-1/50000s, NTSC: 1/30s-1/50000s |
| Image | Description |
| Exposure Mode | UAC-B115-AF28:Four modes: Global(default), BLC, HLC, DWDR |
| Day/Night | UAC-B115-AF28:Three modes: Auto (default), Day, Night |
| Digital Noise Reduction | UAC-B115-AF28:2D |
| White Balance | UAC-B115-AF28:Two modes: Auto (default), Manual |
| WDR | UAC-B115-AF28:DWDR |
| Smart IR | UAC-B115-AF28:Support |
| Flip | UAC-B115-AF28:Supports 180°horizontal flip, 180°vertical flip |
| Digital Defog | UAC-B115-AF28:N/A |

| Audio | Description |
|-----------------------|---|
| Built-in Mic | UAC-B115-AF28:Support |
| Camera Audio | UAC-B115-AF28:TVI: 5MP@20fps, 5MP@12.5fps, 4MP@25fps, 4MP@30fps, 1080P@25fps, 1080P@30fps CVI: 5MP@25fps, 4MP@25fps, 4MP@30fps |
| Interface | Description |
| Power Interface | UAC-B115-AF28:5.5 mm Power Interface |
| Video Output | UAC-B115-AF28:BNC, supports TVI/AHD/CVI/CVBS |
| Operating Environment | Description |
| Temperature | UAC-B115-AF28:-30 °C ~ 60 °C (-22 °F ~ 140 °F) |
| Humidity | UAC-B115-AF28:≤95% RH (non-condensing) |
| Surge Protection | UAC-B115-AF28:4kV for power&4kV for video output interfaces |
| General | Description |
| Power | UAC-B115-AF28:DC12V±25% |
| Power Consumption | UAC-B115-AF28:MAX 3.3W |
| Mount | UAC-B115-AF28:Corner Mount&Pole Mount |
| Dimensions | UAC-B115-AF28:142mm*63mm*65mm (L*W*H) |
| Material | UAC-B115-AF28:Plastic |
| Weight | UAC-B115-AF28:138g(0.30lb) |
| OSD Menu Language | UAC-B115-AF28:11 Languages English, German, Spanish (Latin America), French, Italian, Japanese, Korean, Polish, Portuguese (Brazil), Russian, Turkish |
| Certification | Description |
| EMC | UAC-B115-AF28:CE-EMC (EN 55032, EN 61000-3-3, EN IEC 61000-3-2, EN 55035); FCC (FCC 47 CFR part15 B) |
| Safety | UAC-B115-AF28:CE-LVD (EN 62368-1) |
| Environment | UAC-B115-AF28:CE-RoHS (2011/65/EU;(EU)2015/863); WEEE (2012/19/EU) |
| Protection | UAC-B115-AF28:IP67 (IEC 60529) |

Dimensions

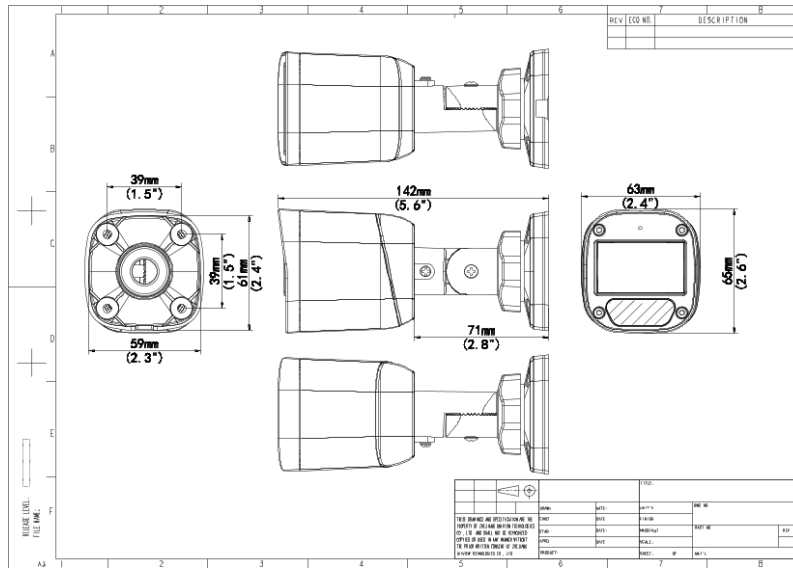

Zhejiang Uniview Technologies Co., Ltd.

No. 369, Xietong Road, Xixing Sub-district, Binjiang District, Hangzhou City, 310051, Zhejiang Province, China (Zhejiang) Pilot Free Trade Zone, China

Email: overseasbusiness@uniview.com; globalsupport@uniview.com

<http://www.uniview.com>

©2023-2024 Zhejiang Uniview Technologies Co., Ltd. All rights reserved.

*Product specifications and availability are subject to change without notice.

*Despite our best efforts, technical or typographical errors may exist in this document. Uniview cannot be held responsible for any such errors and reserves the right to change the contents of this document without prior notice.